

# Indicating Ringbalance RW65

measuring draft, pressure and differential pressure

## Installation Instructions

E\_RW65

-1-



Read these instructions carefully before use.

Do not blow into the pressure ports.

This instrument contains filling fluid: do not remove from the wall with opened valves!

### 1. Mounting

Loosen cover fastening screws **E** and remove cover. Attach the instrument on the wall through the mounting holes **X**.

Mount the instrument in an **exactly upright** position!

### 2. Valves

Open both valves **V** by turning both screws fully(!) counter-clockwise.



**Important: Incompletely opened valves will cause measuring errors!**

### 3. Locking device

Turn locking screw **A** fully counter-clockwise. The pointer should move to the zero position, now.

### 4. Mechanical Zero Correction

For zero setting, both of the external pressure connections (p+/p-) and both of the valves (V) must be fully opened.

If necessary, correct zero-setting of pointer: turn screw **N** max. +/-90°.

#### Positions of Zero Screw N:

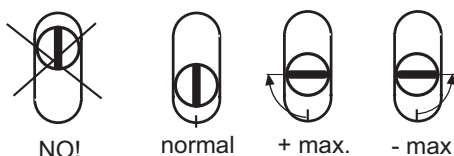

### 5. Additional equipment

If the Ringbalance is supplied with electrical equipment, read the referring instruction, now.

### 6. Close housing

Close housing and fasten cover with screws **E**.

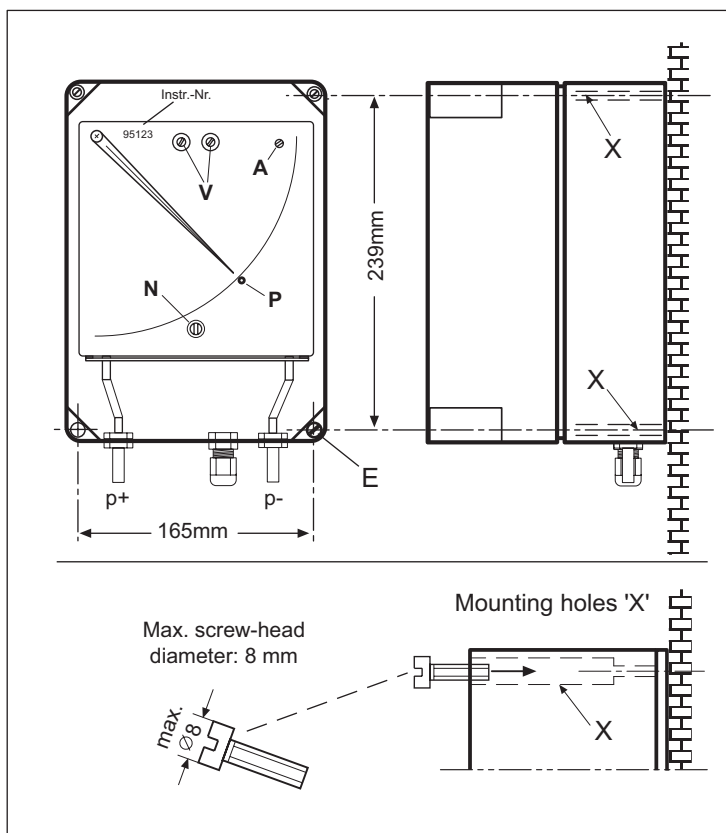

- E** Cover fastening screws (4x)
- V** Valves
- A** Locking screw
- N** Mechanical zero correction
- P** Pointer locking position (red dot)

#### Instr.-N°

When inquiring about your Ringbalance, please include the serial number. This information will assist us in determining all technical specifications of your instrument.

#### Process connections: p+/p-

- Pressure left fitting (p+)
- Draft right fitting (p-)
- Differential pressure higher pressure on the left (p+)  
lower pressure on the right (p-)
- Draft/-Pressure (e.g. -25/0/+25 Pa) left pressure port

# Indicating Ringbalance RW65

## Installation Instructions

E\_RW65

-2-

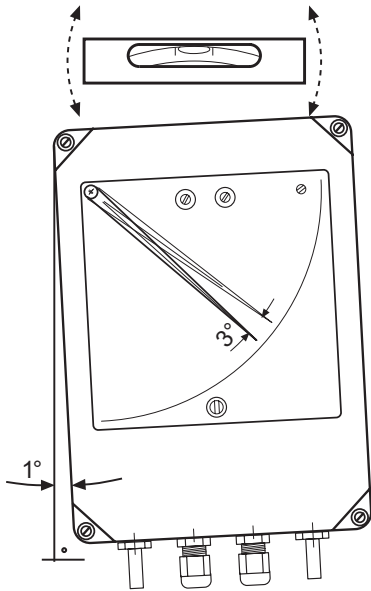

Mount the instrument exactly upright!  
1° deflection of the housing  
causes 3° at the pointer

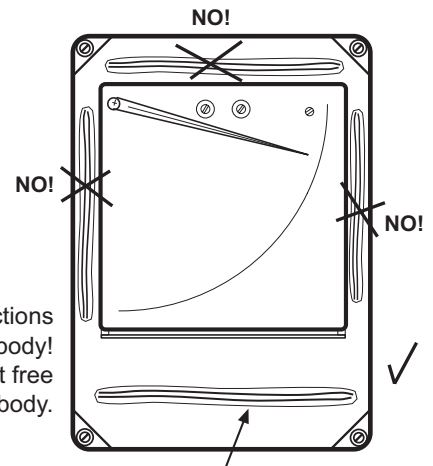

Do not stow the instructions  
beside or above the ringbody!  
This would obstruct free  
rotation of the ringbody.

Place the Installation Instruction here!

### Before Transporting

The Ringbalance instrument contains filling fluid. Before dismantling or transporting, lock down the ringbody with screw **A** (while the pointer is held on the dot **P**), and close both valves **V**!

# The Ringbalance Measuring Principle

E\_RW65

-3-

## Principle

A hollow ring, free to rotate on bearings and half filled with fluid, is divided by partition wall (T) into two chambers. Positive, and negative or differential pressure are applied to the ringbody chambers via flexible tubes. The pressure differential across the dividing wall causes the ringbody to rotate until an equilibrium is reached with counterweight (G).

## Filling Fluid

Since the differential pressure is ultimately balanced by the counterweight, it follows that neither the quantity nor the density of the filling fluid play a role in the actual measurement. However, these two factors are subject to the following criteria:

**Maximum Quantity:** the ringbody should be filled up to the filling opening (see fig.4).

**Minimum Quantity:** if oil spills out because of improper operation or handling (overpressure; tipping over, etc.), the instrument **must be checked** to confirm that the maximum measuring range value can still be reached:

## Quantity Check:

Carefully (!) pressurize the instrument (beware of excessive pressure!). If the maximum of the measuring range can be reached, no oil should be added. However, if the applied pressure comes out of the other pressure connection, and results in "bubbling-through" (figure 3) **before** the maximum range is reached, oil of the same type must be added.

 **Stop pressurizing when the maximum range is reached ! Watch the scale reading !**

## Density (specific gravity)

Although the density of the filling fluid has no direct influence on the actual measurement, it must meet certain criteria. A light oil is suitable for low ranges. For higher ranges, the specific gravity is more critical, since an oil which is too light would experience a large level change and overflow into the flexible tubes before the pointer reaches the maximum value.

### Mineral Oil

density 0.8kg/l, overload point at 1 kPa (4" W.C.)  
max. range 700 Pa

### Synthetic Oil

density 1.9 kg/l, overload point at 2 kPa (8" W.C.)  
max. range 1.8 kPa (7" W.C.)

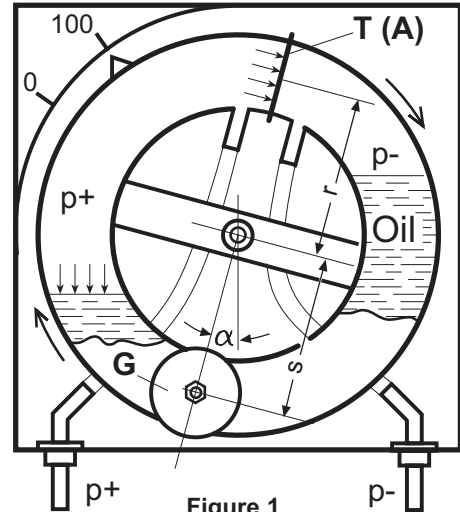

Figure 1

$$\Delta p = \frac{G \times s}{A \times r} \sin \alpha$$

$\Delta p$  ... Differential Pressure [Pa]

G ... Counterweight [N]

A ... Area of partition wall T [m<sup>2</sup>]

r ... Average Ringbody Radius [m]

s ... Counterweight Moment Arm [m]

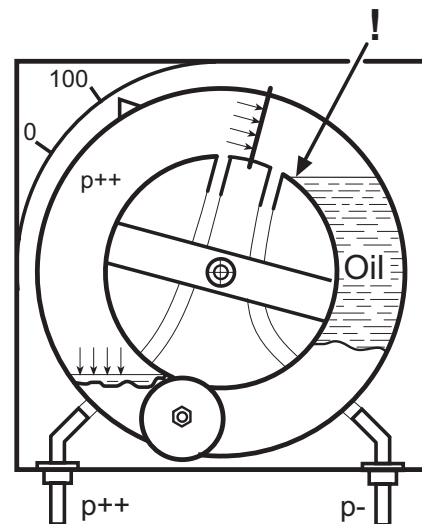

Figure 2  
(near the overflow point)

## Refilling / Overload / Functional Check

E\_RW65

-4-

### Refilling (figure 4)

In the event that the filling fluid has to be replenished, remove the filling plug (F) and add fluid, using a funnel and tube, until the fluid comes out of the filling opening.

The Ringbalance must be in its normal upright position during this process, and the ringbody valves (V) and pneumatic lines must be **open**.

### Overload

The calibration of a Ringbalance instrument is determined by the mass of the counterweight, which is accurately adjusted at the factory.

A counterweight cannot "age" or become "overloaded". Therefore, Ringbalances can occasionally be loaded to the maximum and even overloaded without affecting their mechanical calibration.

The critical point is reached when the oil rises so high that it overflows into the flexible tube.

This **overflow point** (fig. 2) is actually determined by the density of the fluid used, not by the measuring range.

For example, a Ringbalance filled with mineral oil (density 0.8kg/l) is protected to 1 kPa (4" W.C.), even if it has a range of only 0-50 Pa (0.2" W.C.).

With synthetic oil (1.9 kg/l), the Ringbalance is protected to 2 kPa (8" W.C.).

If higher pressures are expected, a special protective device must be installed (type "DZ1").

### Functional Check

If, through any circumstances, a part of the filling fluid spills out, the following functional check is recommended:

First, determine if the maximum measuring range is reached or if some oil must be added (see section above: "**Quantity Check**"). Refill, if necessary.

Next, determine if the Ringbalance is **correctly zeroed** (see above: "**Zero Correction**").

**The Ringbalance is most likely to be functioning correctly when:**

1. **the maximum value can be reached**
2. **when the instrument can be exactly "zeroed"**

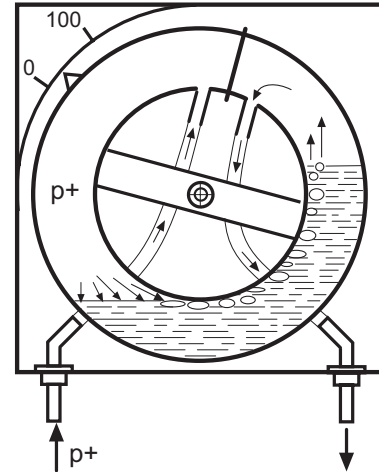

Figure 3  
("Bubbling through")

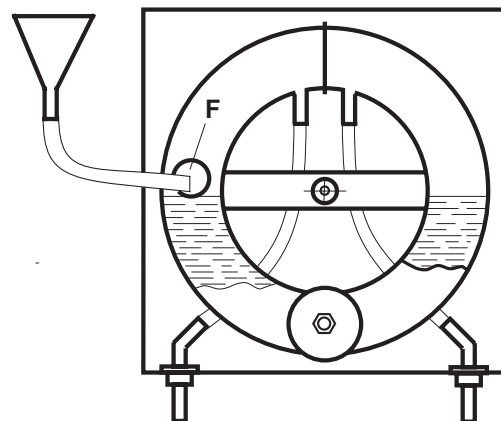

Figure 4:  
(Replenishing the filling fluid)

**RIXEN** GmbH & Co KG

Kornweg 1

D-44805 Bochum (GERMANY)

Tel.: +49 (0)234 86790 ~ Fax: +49 (0)234 850130

eMail: rixen-ringwaagen@t-online.de

www.rixen-gmbh.de